



RevV4 Ceramic Rotary Valves

Hankscraft Runxin's RevV4 valves are designed with high flow rates to handle most residential or light commercial applications. They feature innovative, patented ceramic discs for ultimate performance and reliability. The discs are abrasion and corrosion resistant, extending the life of the valve and significantly reducing maintenance costs.

RevV4 valves have 7 advanced programming options with fully adjustable cycles to minimize water usage during regeneration. They utilize up-flow regeneration which efficiently washes the media, exchanging more grains per pound of salt. RevV4 valves have signal output for external devices, program functions that remain in long-term memory, and 72-hour memory backup should a power outage occur, giving you the confidence that your customers are receiving a cost-effective, high-quality water treatment solution.

Hankscraft Runxin's RevV4 valves have an interlock function to connect multiple valves in series or in parallel. There is an alternate interlock function, used with twin demand systems and 3-way ball valves to supply treated water 24/7. The RevV4's simple, yet powerful user interface has an easy to read LCD display and the valve offers remote handling to accept input from a PLC or computer. Advanced work modes are available with adjustable settings and three different cycle sequences to get the exact configuration needed for your job.

RevV4 Valves Feature:

- Patented ceramic discs are corrosion and abrasion resistant for longer life and reduced maintenance
- Multiple, programmable efficiency settings; grains exchanged per lb. of salt
- Bright, easy to read LCD display
- Long-term memory for program functions
- 72-hour memory backup
- No external PLC required to operate multiple control heads or external devices
- 4 language options: English, Spanish, Chinese, and French

Contact a local Hankscraft Runxin dealer for your custom water treatment solution!



This valve is Tested and Certified by NSF International against NSF/ANSI Standard 44 for materials and structural integrity requirements

COMPONENT

RevV4 Ceramic Rotary Valves

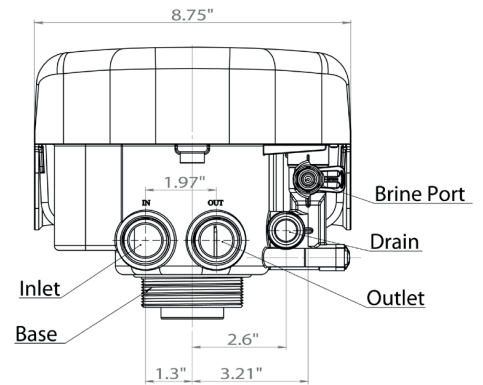
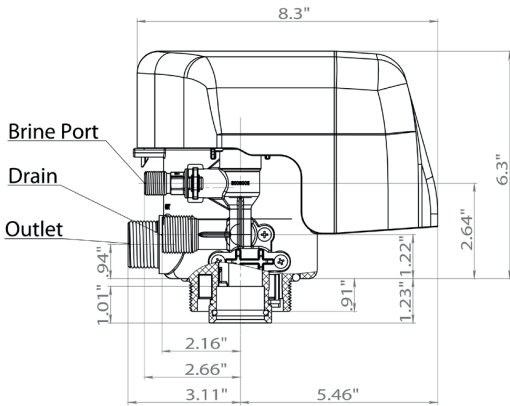

Dimensions

Width	Height	Depth
8.75"	6.3"	8.3"

Electrical Specifications

Transformer Input	Transformer Output	Wattage
100-240VAC / 50-60Hz	12VDC / 2A	24W

Operational Specifications

Operational Pressure	Operational Water Temperature	Inlet Water Turbidity
20 - 120 psi	35° F - 125° F	< 5NTU

Control Valve Parameters

Inlet	Outlet	Drain	Brine	Base	Riser Tube	Hard Water Bypass
1"	1"	1/2" Barbed	3/8"	2.5" - 8NPSM	32mm	Yes

Flow Rate (Valve Only)

Service @ 15 psi Drop	Peak Service @ 25 psi Drop	Peak Backwash @ 25 psi Drop	CV Service @ 1 psi Drop
21 gpm	25.5 gpm	7 gpm	5.56 gpm

Additional Specifications

Valve Material	Height From Top of Tank	Meter Accuracy	Weight
Noryl® Plastic	7" / 180mm	±5%	2.27kg / 5.0 lbs.